

SCHNEEBERGER

LINEAR TECHNOLOGY

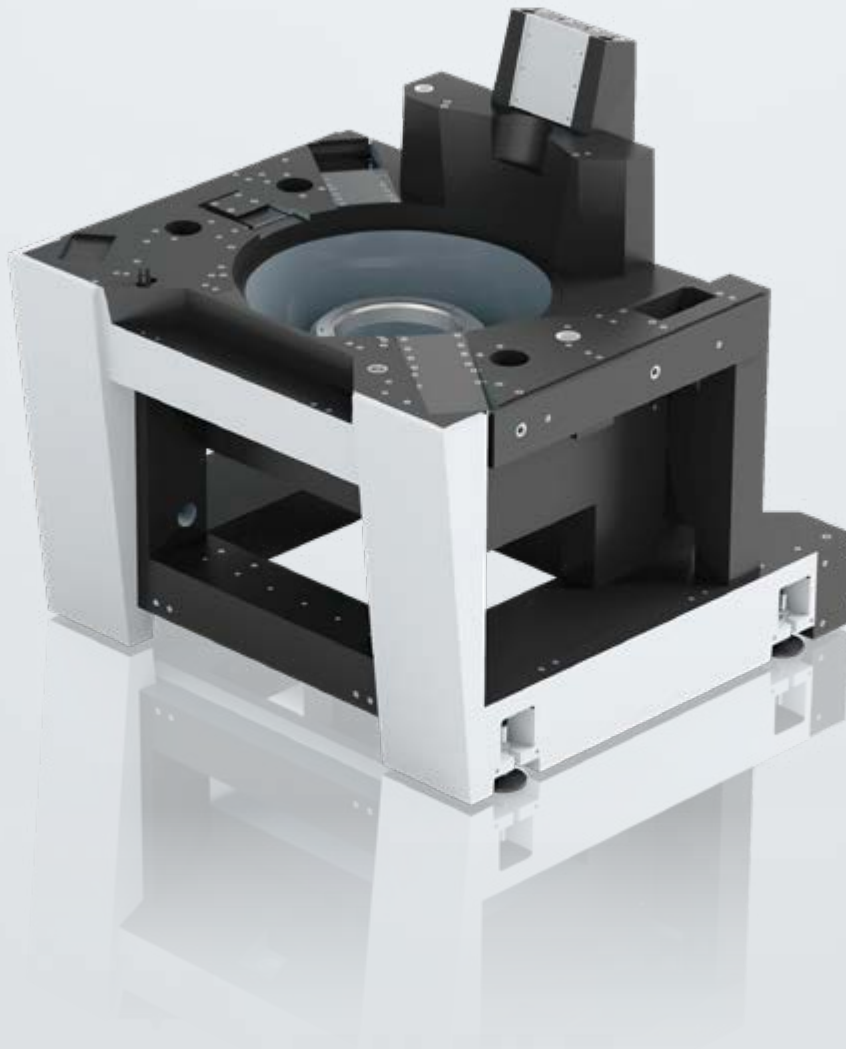

Mineral casting

for optimum performance

Product catalog

The most modern plant in Europe.

Schneeberger opts for mineral casting.



Schneeberger Mineralgusstechnik is located in the Czech Republic, close to the German border and just 10 minutes' drive from the A93 highway from Munich to Berlin. It has quickly become the most modern facility of its kind in the whole of Europe, with over 120 specialist employees.

Schneeberger Mineralgusstechnik has a joint venture operation with Fritz Studer AG. This draws together the many years of experience and technical expertise. Our many years of experience with mineral casting, its range of applications and the excellent product characteristics make us a strong and reliable partner – and not just for machine tool manufacturers.

Our global presence and our strong sales and support structures guarantee that we are available to our customers in all the major industrial economies. As well as enabling us to provide a comprehensive range of logistical services, this also ensures that we can offer intensive local customer support, right from the very start of the planning phase.

Present in the most important future markets.

Schneeberger Mineralguss also has production facilities in China.

Asia is one of the most important developing markets for the machine tool sector. Until now, mineral casting was very limited there. However, there is significant demand, both from Asian companies and from European customers who produce in Asia.

We have been producing mineral castings in China since 2010. We have invested in our own purpose-built mineral casting works at our site in Changzhou, to the west of Shanghai.

This has enabled Schneeberger Mineralgusstechnik to continue the success of its European history in Asia.

The finished product, right on the assembly line.

How we help to give our customers a competitive advantage.

Schneeberger Mineralgusstechnik provides our customers with a finished, ready-to-use product for final assembly. Depending on the customer's wishes, this can be supplied with:

- Precision surfaces
- Threaded inserts and other cast-in components
- Reference surfaces
- Coated surfaces

Because we can bring several small stages together in the process, our customers benefit from very short processing times – which in turn gives them decisive savings in both the time and cost of their production processes.

We use the latest technology to produce challenging high-accuracy surfaces, along with the relevant tools and templates.

Parts produced in mineral casting are subject to very strict quality assurance measures. This means that our customers can be sure that even complex machine structures and sub-assemblies are produced to the specified dimensions and to the highest quality. We use the very latest measuring instruments to check our high-precision work, and we record the results in our comprehensive measurement reports.

The consistent high quality of our products is demonstrated by the fact that time and again, the reliability and quality of our customers' equipment is recognised by their own customers.

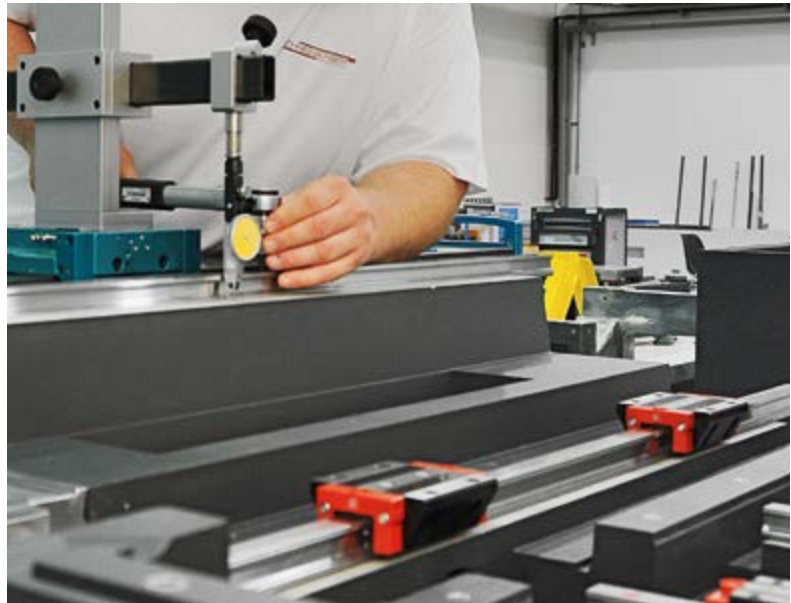

A one-stop solution.

Combining linear technology with mineral casting offers unbeatable customer benefits.

Schneeberger is a leading global manufacturer of mineral castings. As well as innovative and high-precision mineral casting solutions, Schneeberger also offers fully-assembled bases and systems. Depending on the customer's requirements, these can be equipped with the following components:

- Linear bearings
- Linear motors
- Electronics and sensor technology
- Drive units

Because we offer a one-stop solution, we can guarantee that the various different components will work well together.

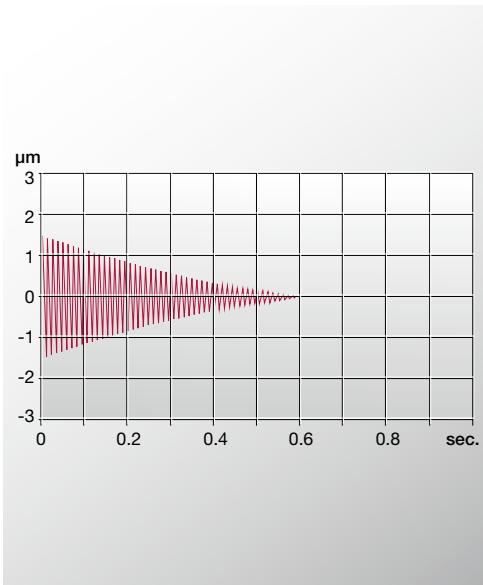

Excellent vibration damping for maximum speed



Parts and systems can be simply cast using mineral casting



KEY CUSTOMER BENEFITS

Mineral casting for optimum performance.

Whether they are light 80 gram units or weigh in at 30 tonnes, our products offer clear benefits for our customers.

Mineral casting has been used for many years as an alternative to cast iron and steel structures, and is now the preferred technology for a wide range of applications. The use of mineral casting means that new applications are opening up in the electronics and medical technology sectors. Here is a quick overview of five of the main customer benefits that mineral casting offers:

1. Greater vibration damping offers higher speeds and greater precision for the end products.

The damping offered by Schneeberger's mineral casting is up to ten times better than that offered by steel or cast iron. This provides extremely high dynamic stability for the machine structure. So it is no surprise that Schneeberger products are used by high-end customers in most sectors, right around the world.

2. A combination of cost-effectiveness and precision.

In many instances, the mineral cast components are cast to the final dimensions because virtually no contraction takes place during hardening – or it is compensated for immediately. We use the latest technology to produce high-accuracy surfaces. And because our final assembled mineral casting offers particularly short processing times, our customers get clear competitive advantages.

3. Flexible shaping for a wide range of products.

Our mineral casting technology provides an exceptional degree of freedom with respect to the shape of the components. The material's specific characteristics even allow for unconventional processes such as bonding, which in turn allows complex product structures to be produced. And because of this freedom in the shaping of products, the material is also ideal for small applications, such as medical laboratory equipment. Our unique range covers products weighing just 80 grams, right through to products that weigh 30 tonnes.



Exceptional flexibility in terms of shape



Precision – right through to quality control

BLUECOMPETENCE

Alliance Member

Partner of the Engineering Industry Sustainability Initiative

Excellent energy efficiency thanks to our cold casting process

4. Casting for parts and systems.

Our mineral casting construction technique uses a cold casting process. This makes it simple for us to cast additional components and connections to services into the construction, and also to do the same for sensors and measurement systems. Each part that we integrate into the mineral casting shortens the processing times for our customers, which in turn saves them valuable fitting time.

5. Significantly less CO₂ and reduced energy consumption (Blue Competence®).

Schneeberger Mineralgusstechnik fully supports the «Blue Competence» campaign, an energy and environmental initiative led by the VDW (the Verbands Deutscher Werkzeugmaschinenfabriken, or German Machine Tool Builders' Association). The cold casting process means that mineral casting does not need any additional heat energy during the manufacturing process. The heat is created by an exothermic reaction between the

chemical components. As a result, mineral casting uses less energy and has a better carbon footprint than can be achieved by alternative technologies such as steel and cast iron.

And as an additional environmental bonus, our mineral castings can be fully recycled. When our customers have finished using their mineral casting parts, they can return the products to us and we work with fully certified companies to recycle the material.

A VAST RANGE OF APPLICATIONS

We cover everything!

Schneeberger Mineralgusstechnik covers a very wide range of sectors and products, as you can see from these examples.

Presence:

We have our own local production facilities in both the European and Asian markets, and our own sales offices in all major industrial countries.

Sectors:

The number of areas where mineral casting and techcon® (1) offer unbeatable benefits for our customers is growing fast. Here are some of the main sectors that we are active in:

- Machine tool industry
- Pick & place
- Packing industry
- Laser industry
- Electronics industry
- Optical industry
- Medical technology
- Food
- Flat panel (inspection equipment)

Products:

Our applications cover a full range of sizes. Here are a few examples from different sectors.

(1) techcon® – A specially developed material for "selected applications" and developed as a cost-effective alternative to mineral casting.



Packing industry
Machine structure for blister packaging machine

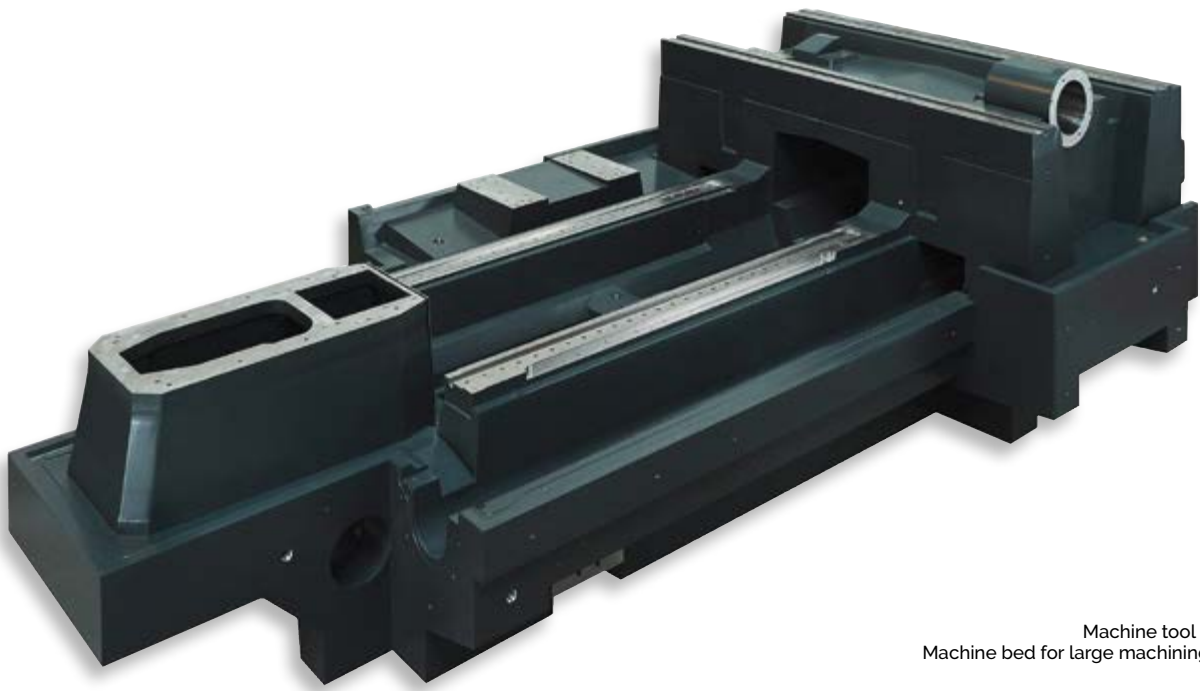

Machine tool industry
Machine bed for large machining center

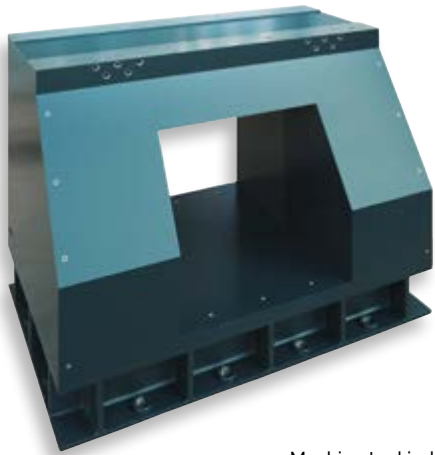

Machine tool industry
Side piece for Gantry machining



Optical industry machine
Structure for high precision lens processing

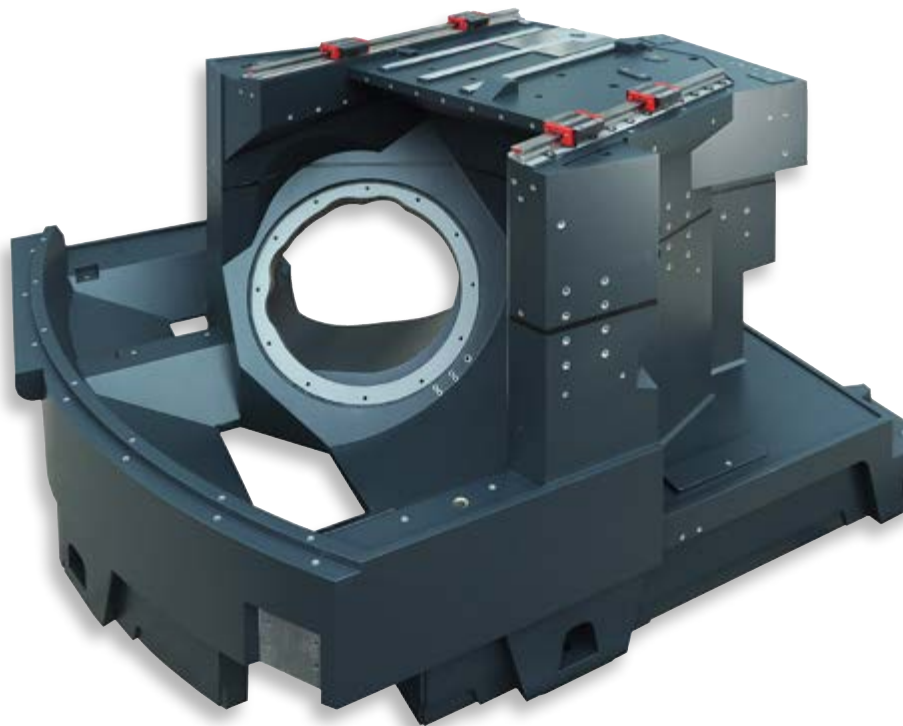

Machine tool industry
Machine structure for demanding 5 axis machining

www.schneeberger.com
www.schneeberger.com/contact

PROSPECTUSES

- CUSTOMIZED BEARINGS
- GEAR RACKS
- LINEAR BEARINGS AND RECIRCULATING UNITS
- MINERAL CASTING SCHNEEBERGER
- MINISLIDE MSQSCALE
- MINI-X MINIRAIL / MINISCALE PLUS / MINISLIDE

- MONORAIL AND AMS PROFILED LINEAR GUIDEWAYS WITH INTEGRATED MEASURING SYSTEM
- MONORAIL AND AMS APPLICATION CATALOG
- SCHNEEBERGER BALL SCREWS SBS
- POSITIONING SYSTEMS
- SLIDES

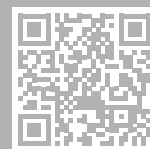

www.schneeberger.com

www.schneeberger.com